

Hodgkin Huxley Model

Instructor: Mark Kramer

Modeling the voltage: biophysics

Goal: Model this,

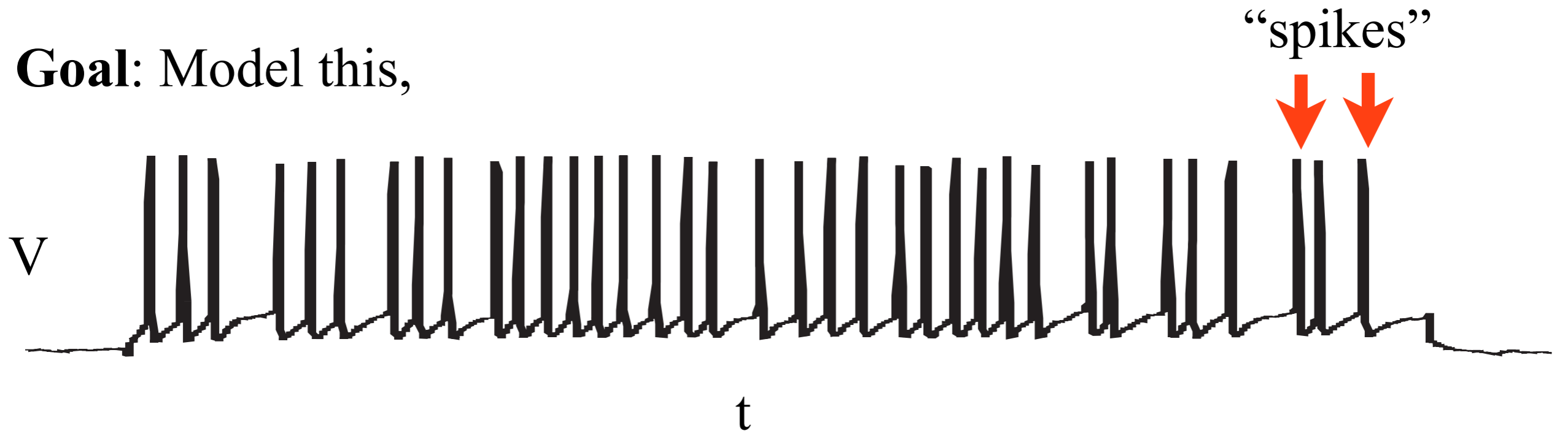

Consider the general expression:

$$dV/dt = f(V, \text{current inputs, time, ...})$$

What else?



We need to choose f ... biophysics.

Modeling the voltage: biophysics

So far: an equivalent circuit capturing some aspects of biophysics:

RC-circuit

Input current: I

*(impermeable
cell membrane)*

capacitor

resistor
(channel)

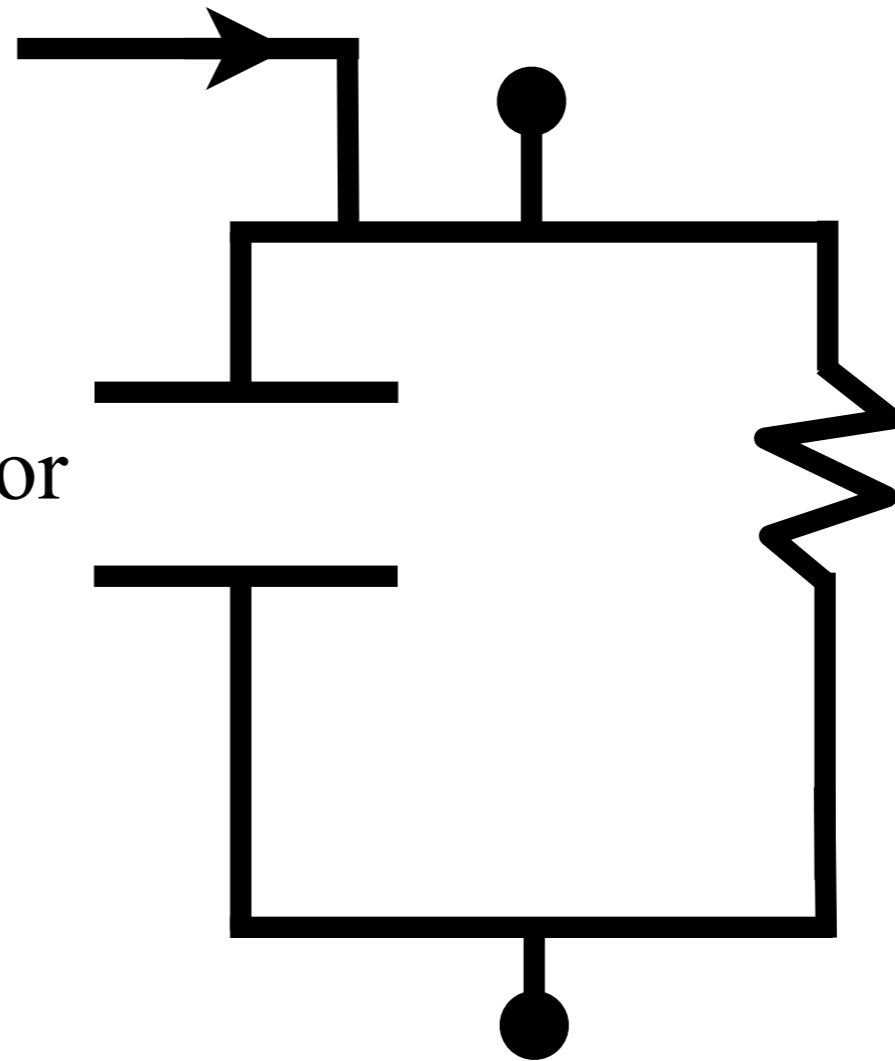

Q: What doesn't this model do?

A: It does not spike on its own.

Now, add more biophysics to increase realism ... and complexity.

Modeling the voltage: biophysics

Fact: some ion channels open and close in time.

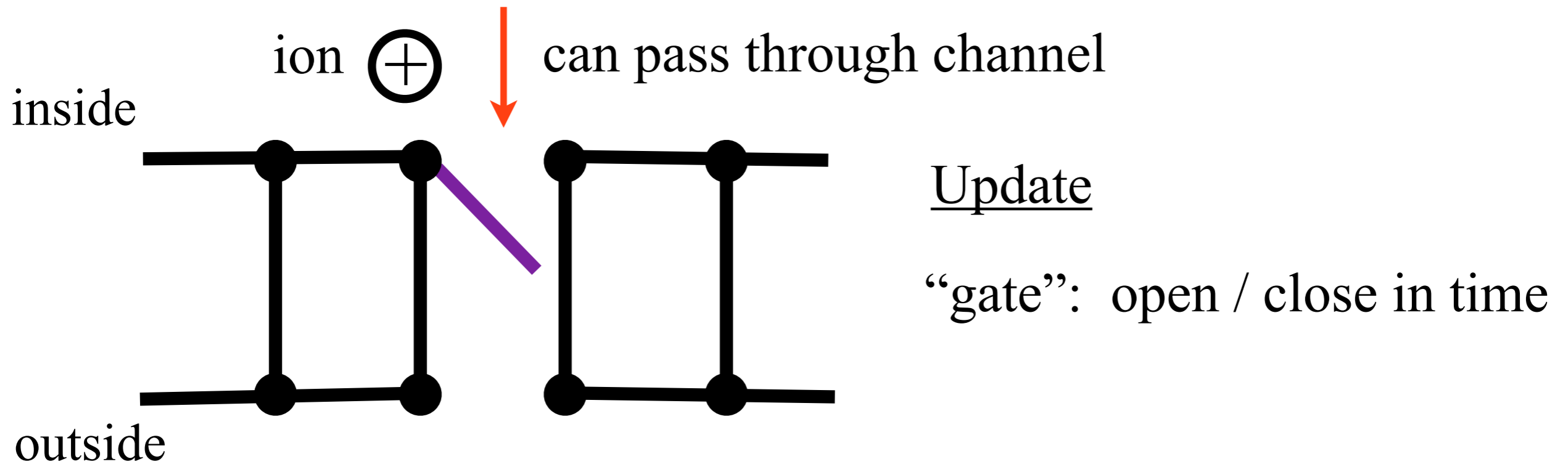

Note: gates are actually proteins that support different conformations.

Our goal: capture the “essence” of behavior, what produces an AP.

model the gate dynamics with differential equations ...

Modeling the voltage: biophysics

Fact: some ion channels open and close in time.

Ex.

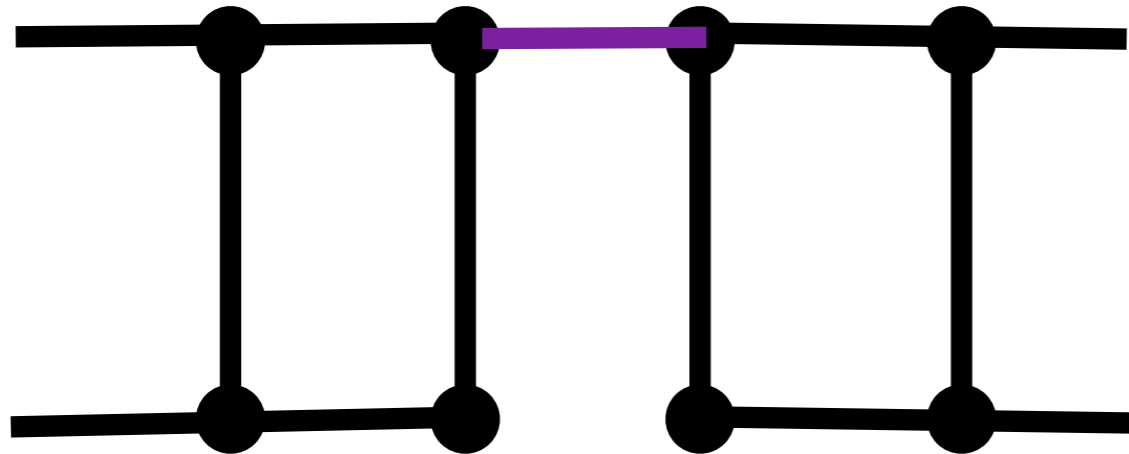

low conductance
gate “closed”
ions flow blocked

Ex.

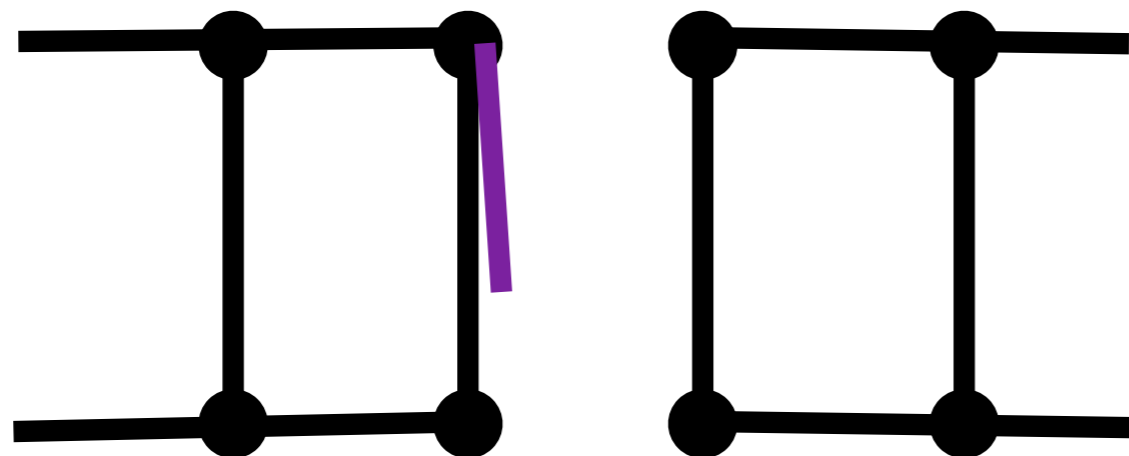

high conductance
gate “open”
ions flow through

Model the dynamics of this gate ...

Modeling the voltage: sodium

Fact: channels are *ion specific*.

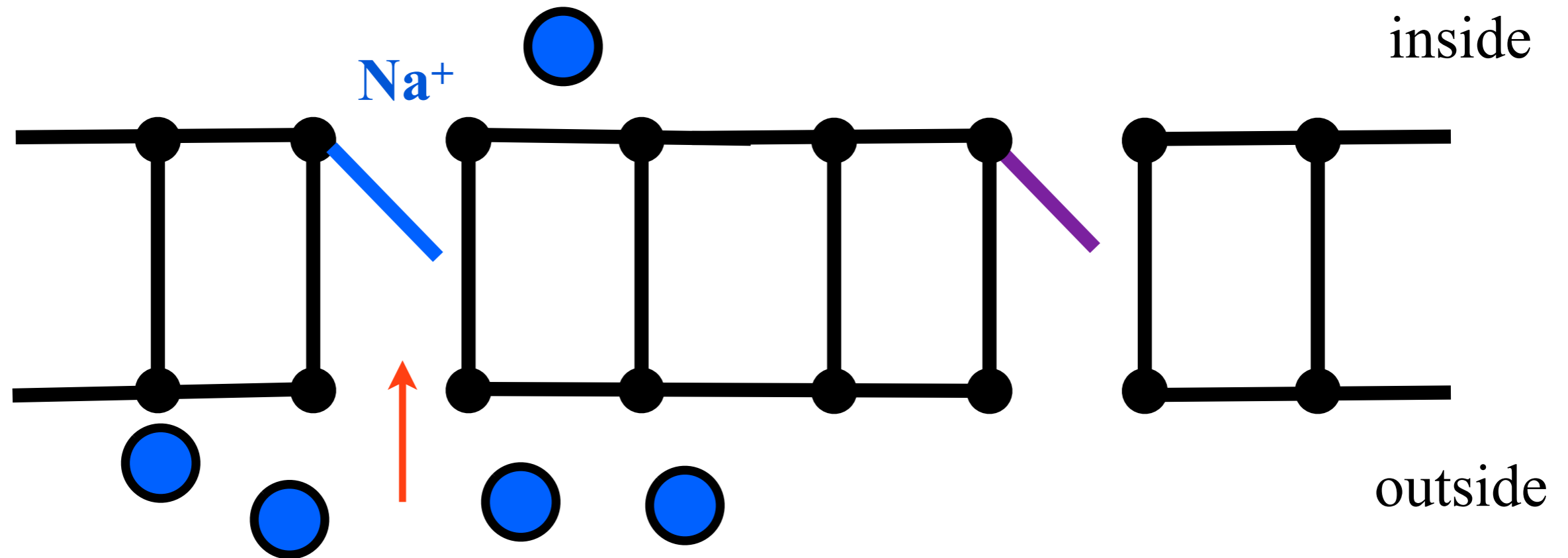

Sodium (Na^+) specific ion channel: only Na^+ may pass.

Fact: $[\text{Na}^+]_{\text{out}} \gg [\text{Na}^+]_{\text{in}}$

So, if the gate is open ... concentration gradient pulls Na^+ into cell.

Q: Impact on neuron's voltage?

Modeling the voltage: sodium

Q: What could prevent Na^+ flow into neuron?

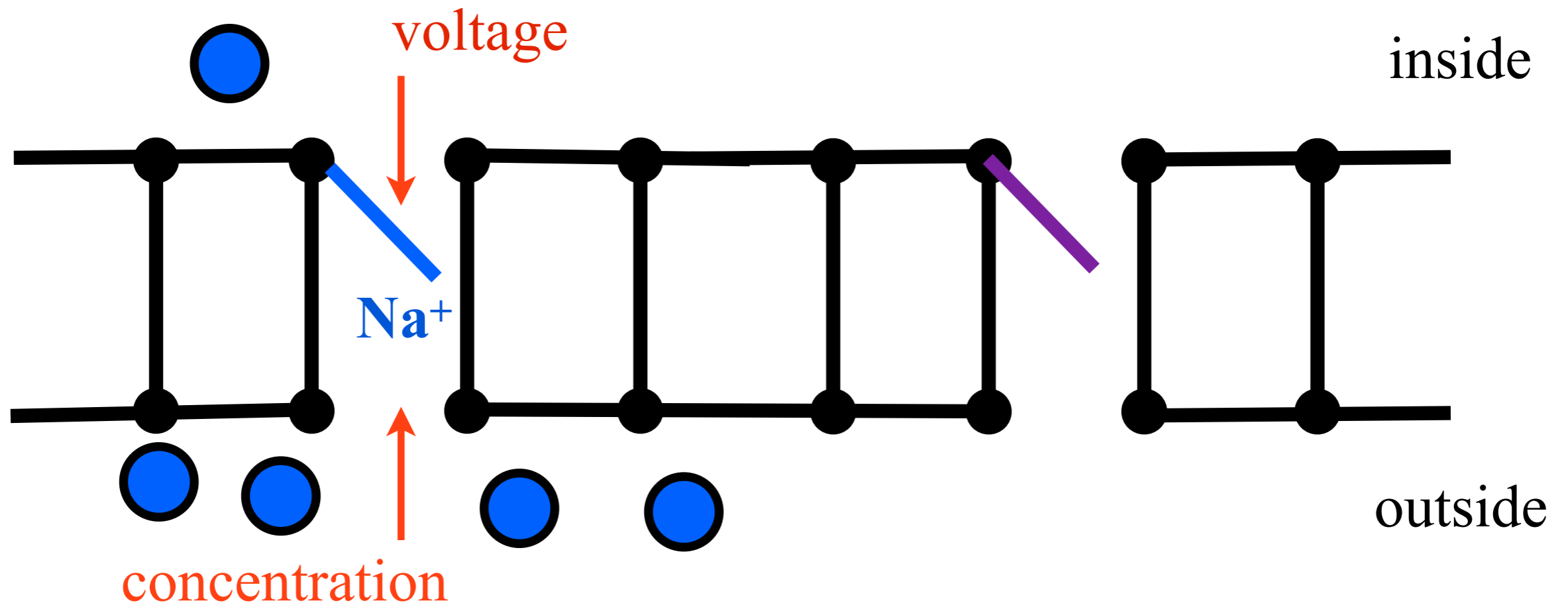

A: Adjust interior voltage make interior voltage very positive.

Fact: positive ions flee high voltages.

at $V_{\text{in}} = + 60 \text{ mV}$ “Nernst potential”

balance the force of concentration gradient and voltage gradient.

Modeling the voltage: sodium

Model Na^+ specific ion channel as an equivalent circuit:

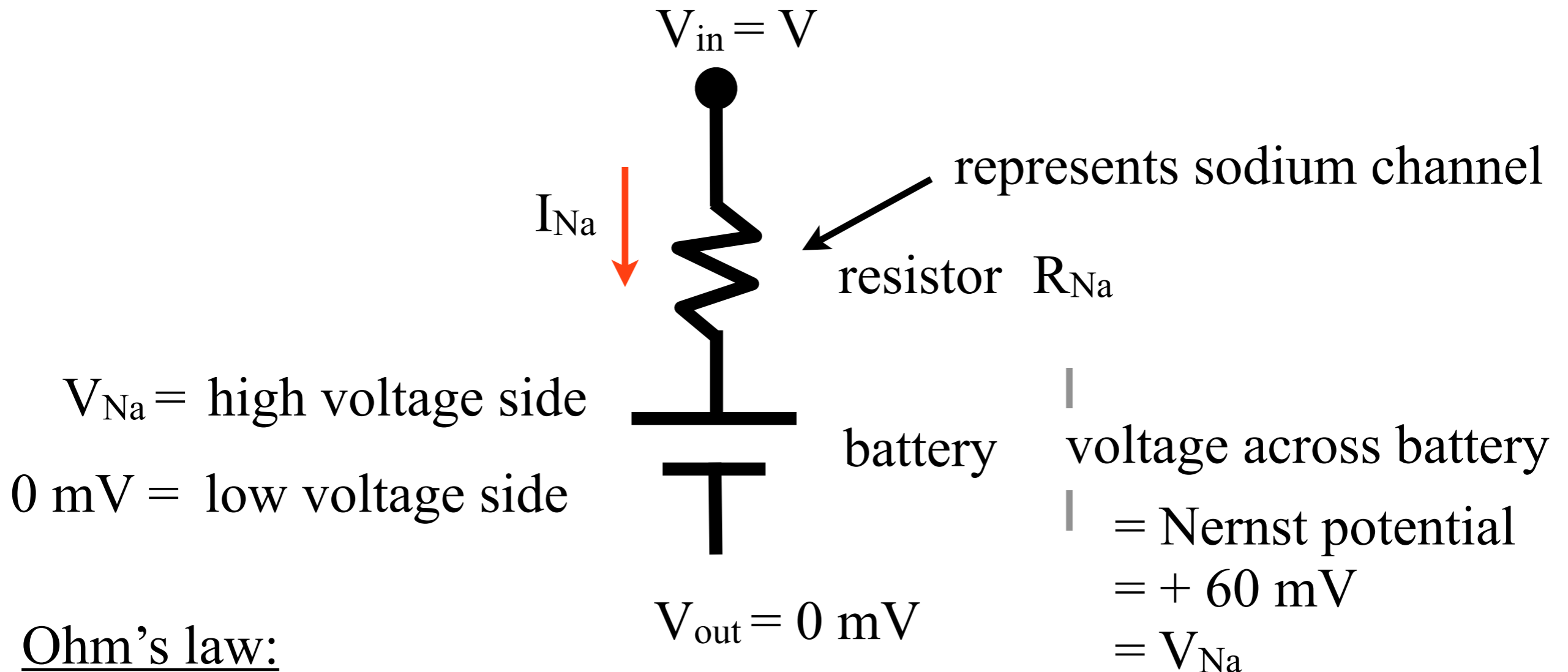

Ohm's law:

$$V = I R$$

$$V - V_{\text{Na}} = I_{\text{Na}} R_{\text{Na}} \quad \text{or}$$

$$I_{\text{Na}} = g_{\text{Na}} (V - V_{\text{Na}})$$

↑ "conductance"

Modeling the voltage: sodium

Implications:

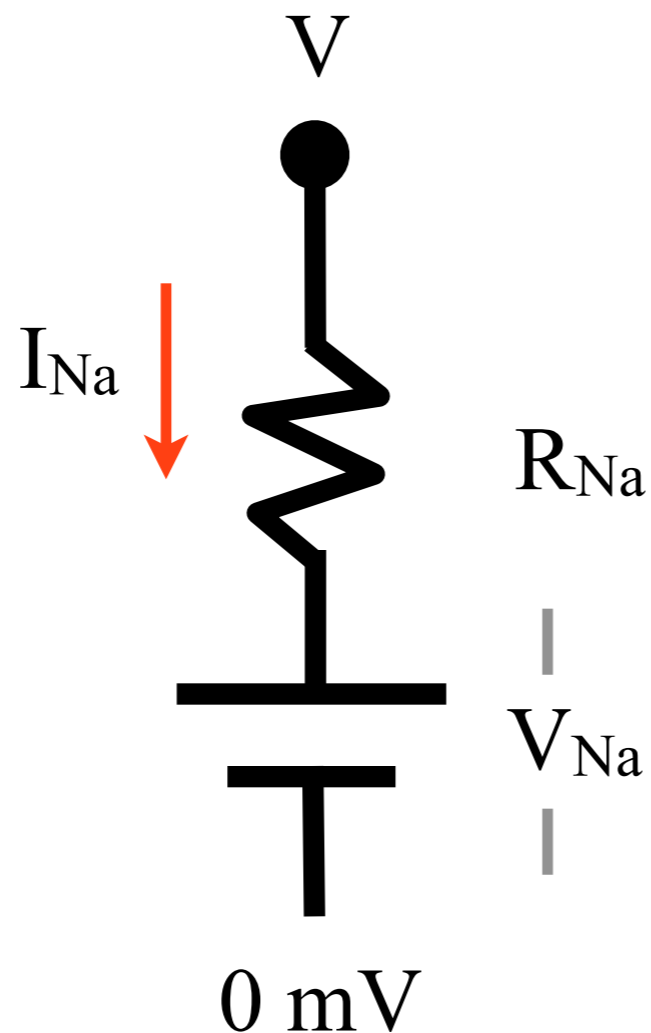

$$I_{\text{Na}} = g_{\text{Na}} (V - V_{\text{Na}})$$

When $V = V_{\text{Na}}$,

$I_{\text{Na}} = 0$ no net current flow through the channel

the cell interior is ... very positive (+60 mV, note “rest” -70 mV)

concentration gradient and voltage gradient ... balance

Modeling the voltage: potassium

Fact: channels are ion specific

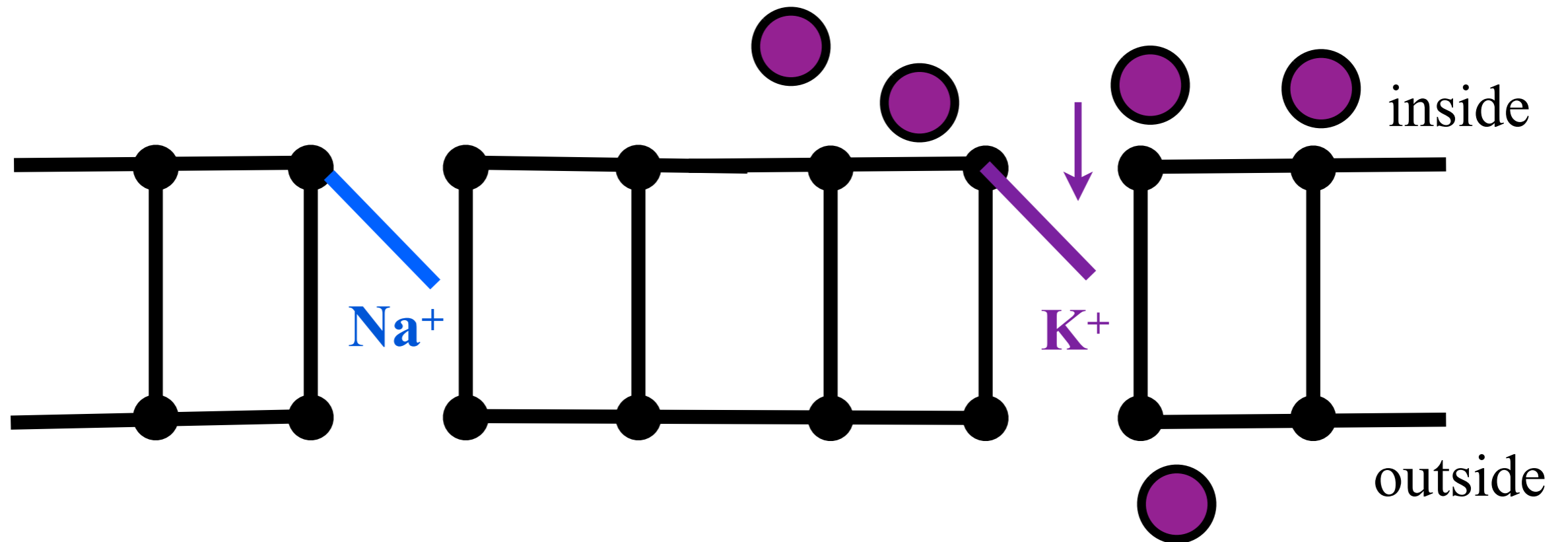

Potassium (K^+) specific ion channel: only K^+ may pass.

Fact: $[\text{K}^+]_{\text{out}} \ll [\text{K}^+]_{\text{in}}$

So, if the gate is open ... concentration gradient pushes K^+ out of cell.

Q: Impact on neuron's voltage?

Modeling the voltage: potassium

Q: What could prevent K^+ flow out of the neuron?

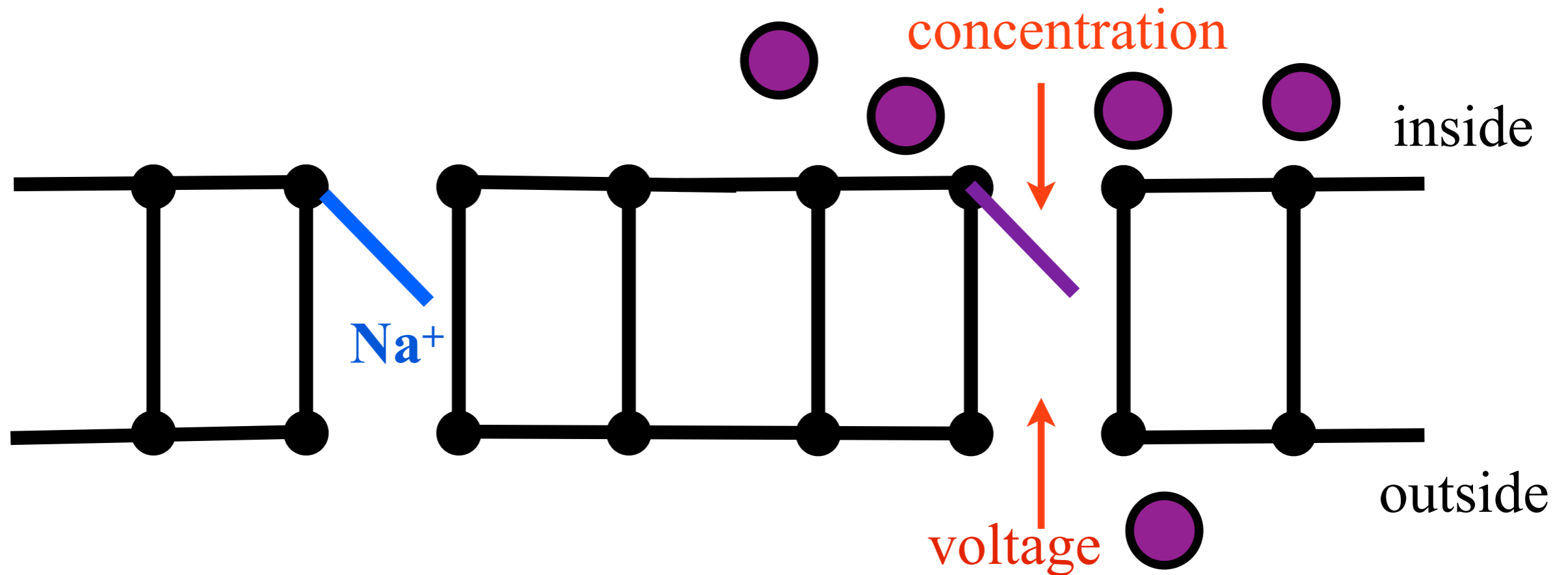

A: Make interior voltage very ... negative

Fact: positive ions approach lower voltages.

at $V_{in} = -77 \text{ mV}$

“Nernst potential”

balance the force of concentration gradient and voltage gradient.

Modeling the voltage: potassium

Model K^+ specific ion channel as an equivalent circuit:

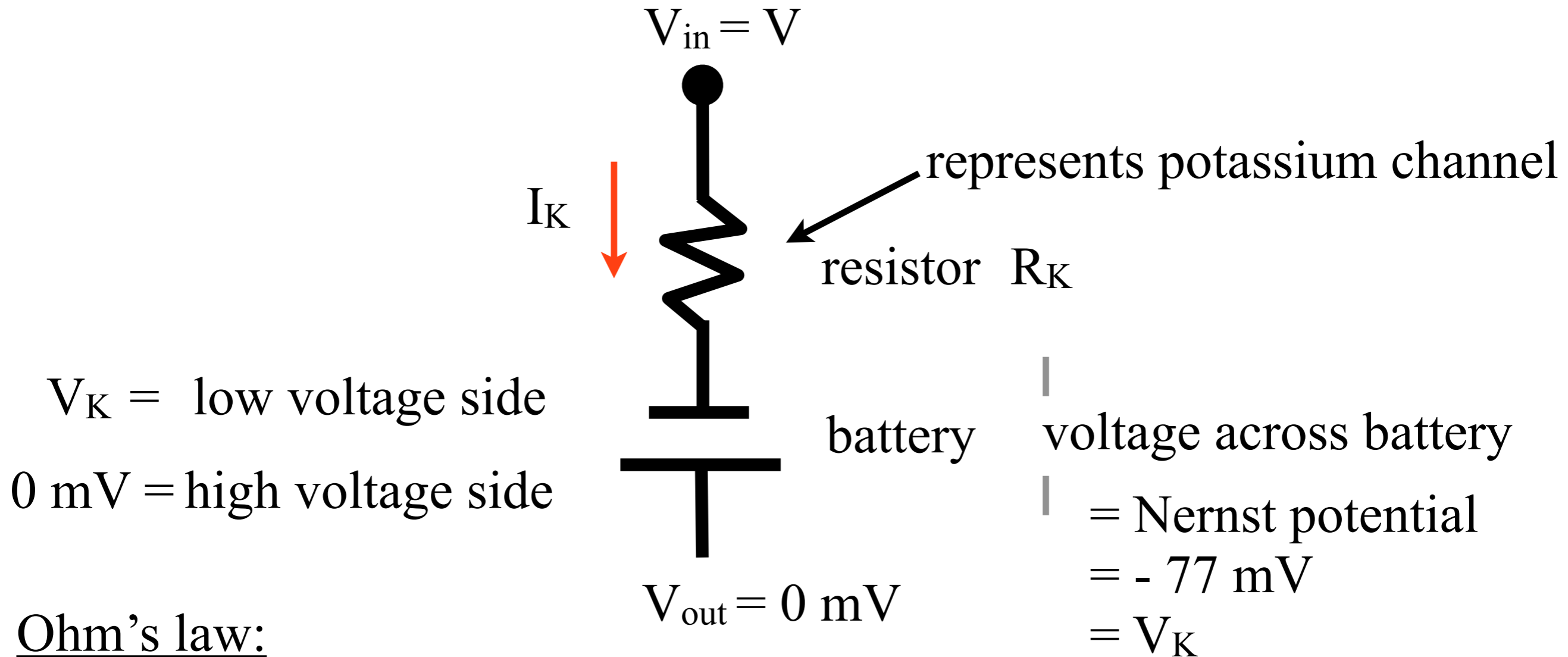

$V_K =$ low voltage side
 $0 \text{ mV} =$ high voltage side

Ohm's law:

$$V = I R$$

$$V - V_K = I_K R_K \quad \text{or}$$

$$I_K = g_K (V - V_K)$$

↑ “conductance”

Modeling the voltage: leak

We'll include one additional channel: "leak" - represents other ions

Model in the same way as Na^+ and K^+ :

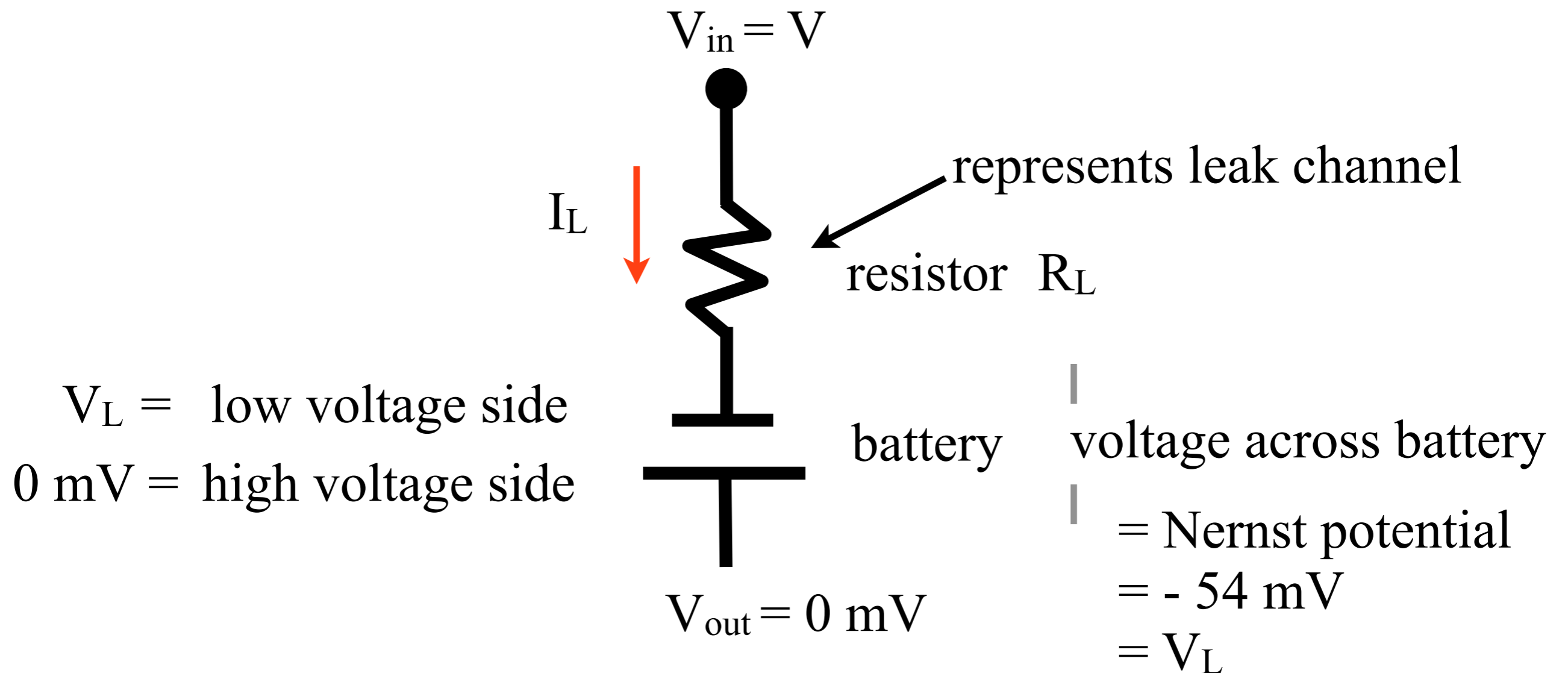

$$I_L = g_L (V - V_L)$$

Modeling the voltage: currents

Our (modified) model has three currents:

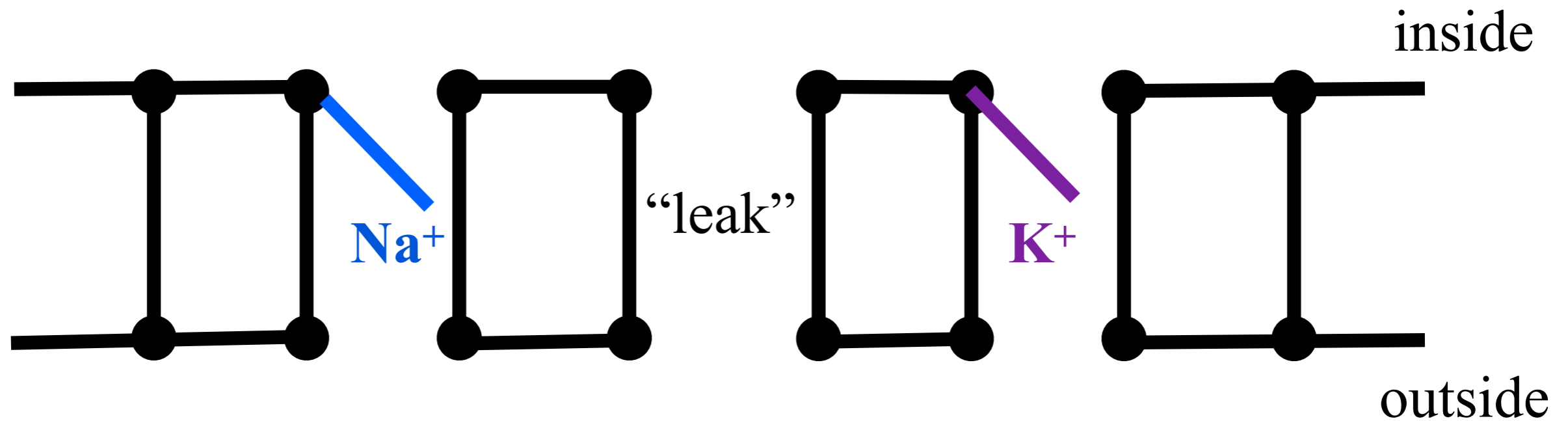

sodium current:

$$I_{\text{Na}} = g_{\text{Na}} (V - V_{\text{Na}})$$

↑
+60 mV

leak current:

$$I_{\text{L}} = g_{\text{L}} (V - V_{\text{L}})$$

↑
- 54 mV

potassium current:

$$I_{\text{K}} = g_{\text{K}} (V - V_{\text{K}})$$

↑
-77 mV

To generate a spike, we need more biology ...

Idea: let the Na^+ and K^+ conductances vary in time.

Modeling the voltage: K^+ variable conductances

Idea: conductances change, channels open/close in time.

Update our models of the conductance

$$I_K = g_K (V - V_K)$$

Replace with: $g_K = \bar{g}_K * p$ ← probability channel is open
↑ maximal conductance (constant)

actually, we'll use: $g_K = \bar{g}_K * n^4$

n = probability that each (of 4) gate is open

$$0 \leq n \leq 1$$

potassium “gating variable”

Modeling the voltage: K^+ variable conductances

Q: Why n^4 ?

A: Visualize the potassium channel as consisting of 4 gates:

Examples:

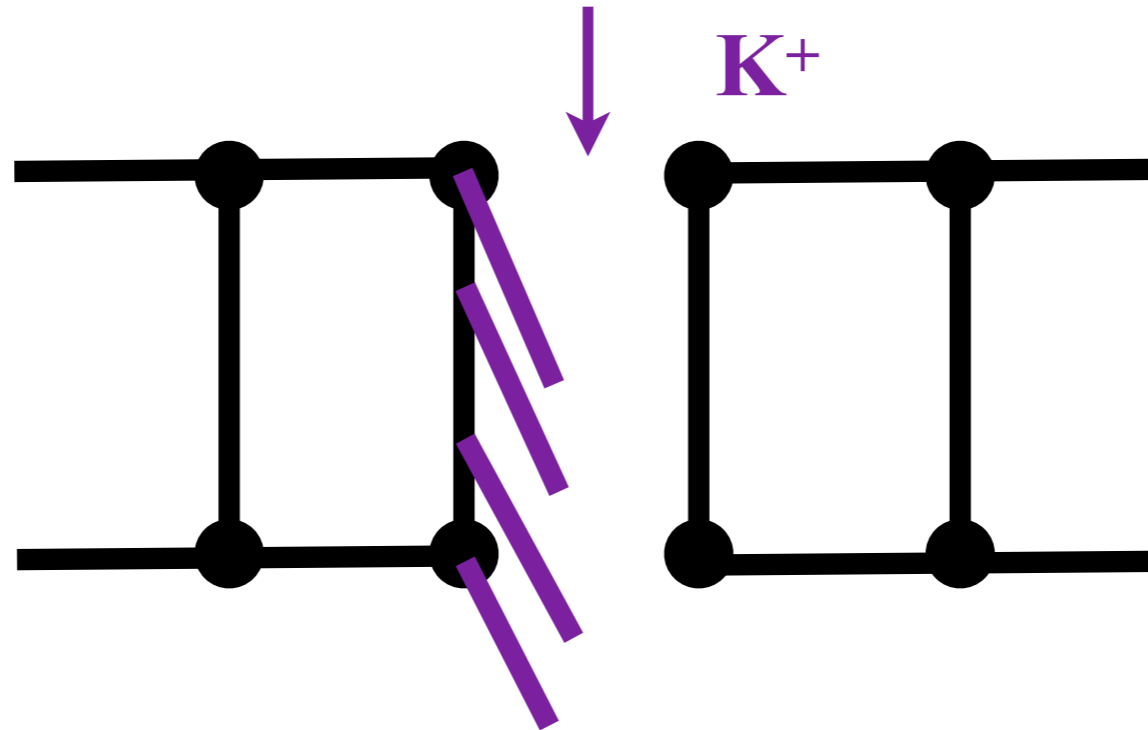

For channel to be open, we need all 4 gates open ...

$$\begin{aligned} \text{channel conductance} &\sim (\text{probability 1st gate open}) && n \\ &* (\text{probability 2nd gate open}) && * n \\ &* (\text{probability 3rd gate open}) && * n \\ &* (\text{probability 4th gate open}) && * n \end{aligned} \quad n^4$$

A: That's what fits the data! [Hodgkin & Huxley, 1952]

Modeling the voltage: K^+ variable conductances

Let's model the dynamics of the gating variable n .

Consider the reaction equation:

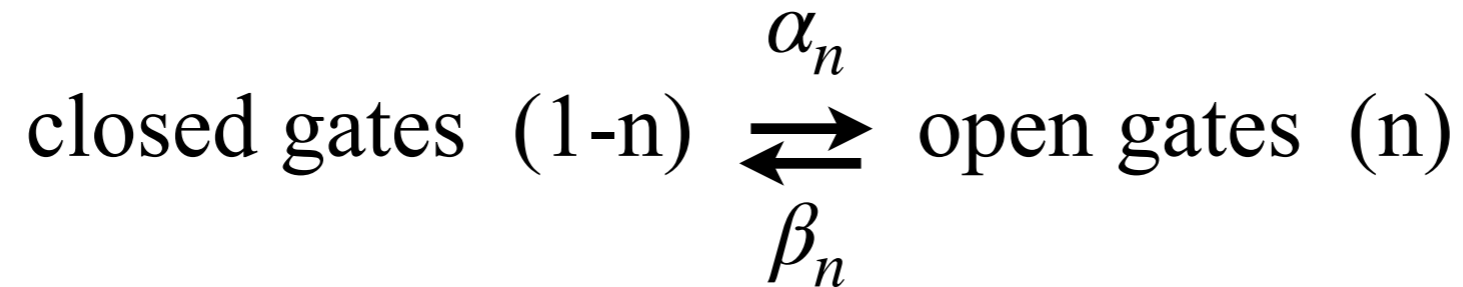

α_n rate of transition: closed to open

β_n rate of transition: open to closed

Motivates the differential equation:

$$dn/dt = \alpha_n (1-n) - \beta_n n$$

or

$$\frac{dn}{dt} = -\frac{n - n_\infty(V)}{\tau_n(V)}$$

$n_\infty(V)$ = steady state value

$\tau_n(V)$ = time constant

Modeling the voltage: K^+ variable conductances

Consider the differential equation,

$$\frac{dn}{dt} = -\frac{n - n_{\infty}(V)}{\tau_n(V)}$$

Q: Where does n go?

A: $n \rightarrow$

Modeling the voltage: K^+ variable conductances

Consider the differential equation,

$$\frac{dn}{dt} = -\frac{n - n_{\infty}(V)}{\tau_n(V)}$$

looks simple, but ... there's voltage dependence.

Q: What are these functions?

A: Note $n_{\infty}(V)$ and $\tau_n(V)$ are functions of α_n and β_n

$$\alpha_n(V) = \frac{0.1 - 0.01(V + 65)}{e^{1 - 0.1(V + 65)} - 1}$$

$$\beta_n(V) = 0.125e^{(-V - 65)/80}$$

Terrible!

Q: Why?

A: It's biology.

Modeling the voltage: K⁺ variable conductances

Visualize the potassium steady state function & time constant:

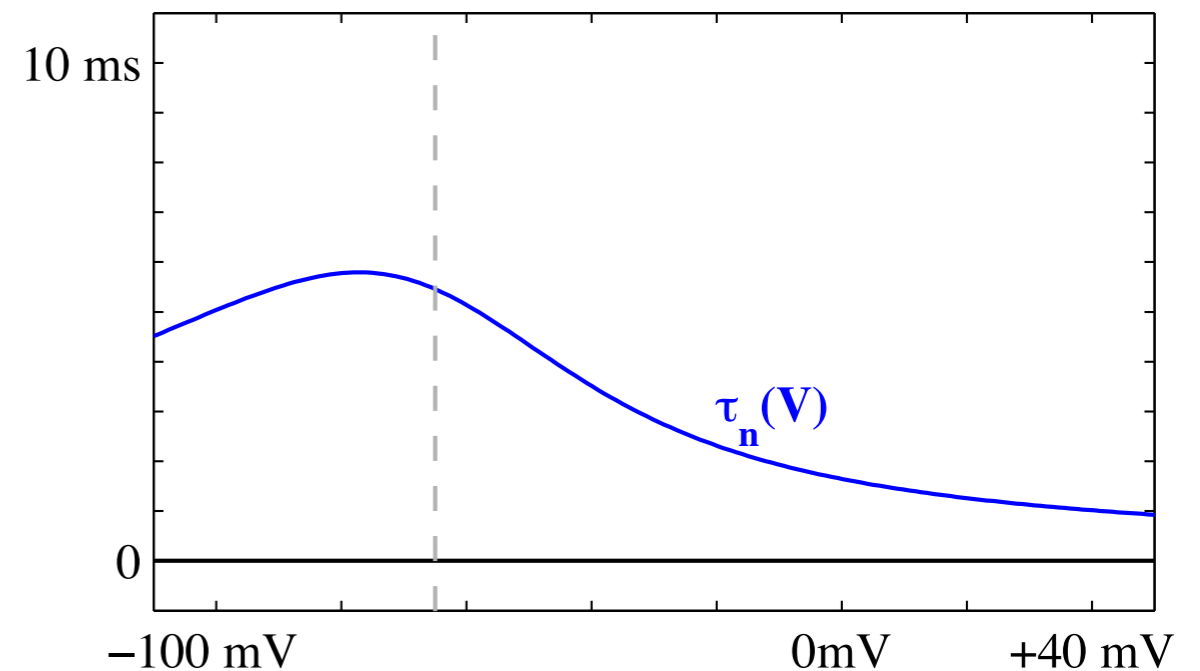
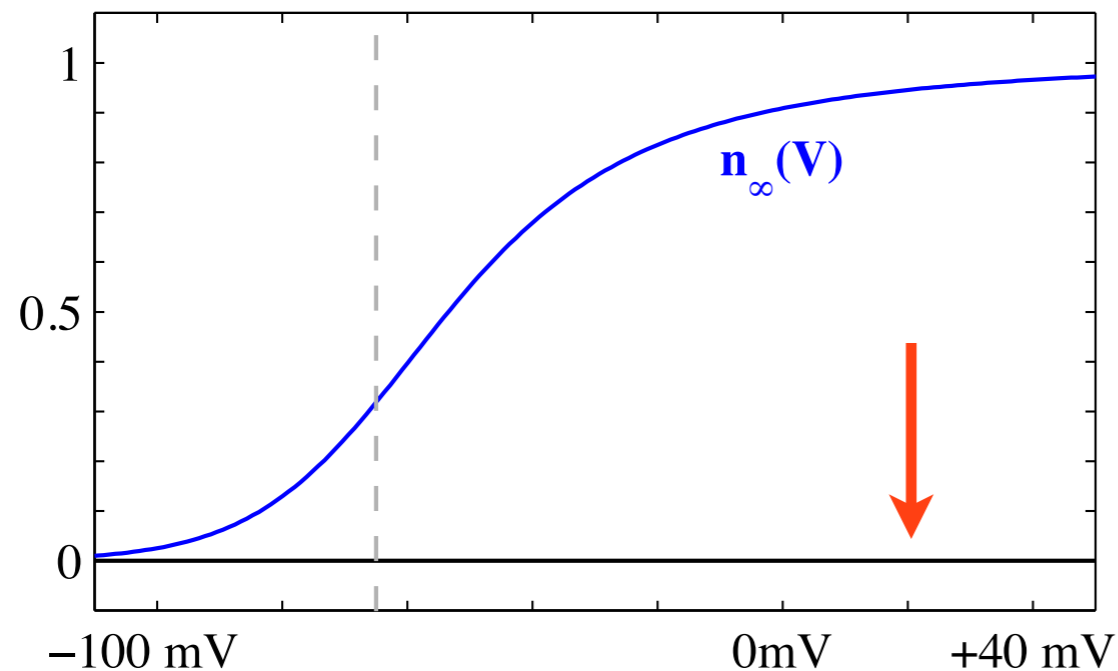

$n_{\infty}[V]$ is the *steady state value* for K,

$\tau_n[V]$ is the *time constant* for K.

So, when neuron is depolarized ...

$n \rightarrow n_{\infty}(V) \sim 1$ potassium channels are ... open
K⁺ flows ... out
voltage ... decreases
potassium channels ... close

Modeling the voltage: Na⁺ variable conductances

In the same way, create a variable sodium conductance ...

$$I_{\text{Na}} = g_{\text{Na}} (V - V_{\text{Na}})$$

$$\uparrow$$
$$g_{\text{Na}} = \bar{g}_{\text{Na}} * m^3 h$$

\uparrow maximal conductance (constant)

m = sodium activation gating variable

h = sodium inactivation gating variable

Gate dynamics:

$$\frac{dm}{dt} = -\frac{m - m_{\infty}(V)}{\tau_m(V)} \qquad \frac{dh}{dt} = -\frac{h - h_{\infty}(V)}{\tau_h(V)}$$

where the steady state and time constants are functions of V ...

Modeling the voltage: Na⁺ gating variables

steady state values for Na

time constants for Na.

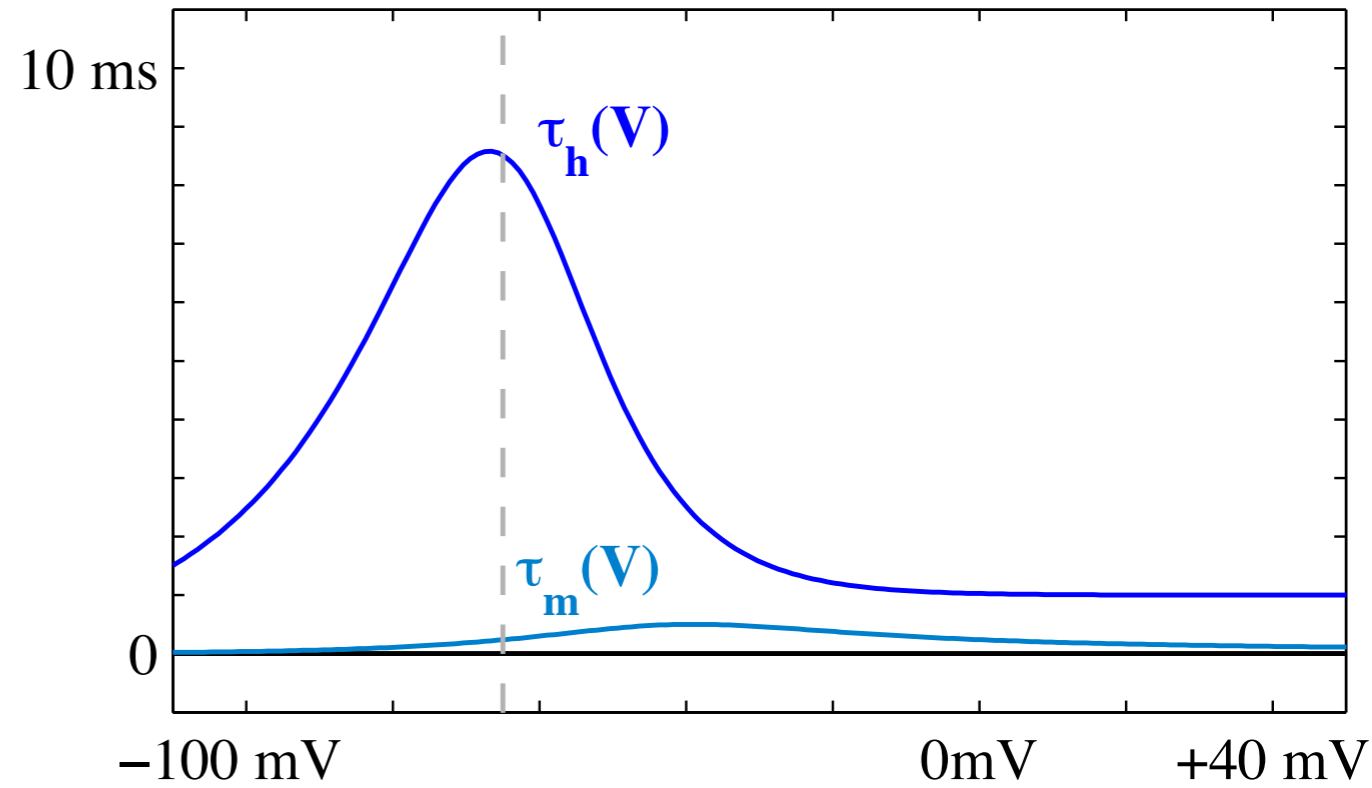
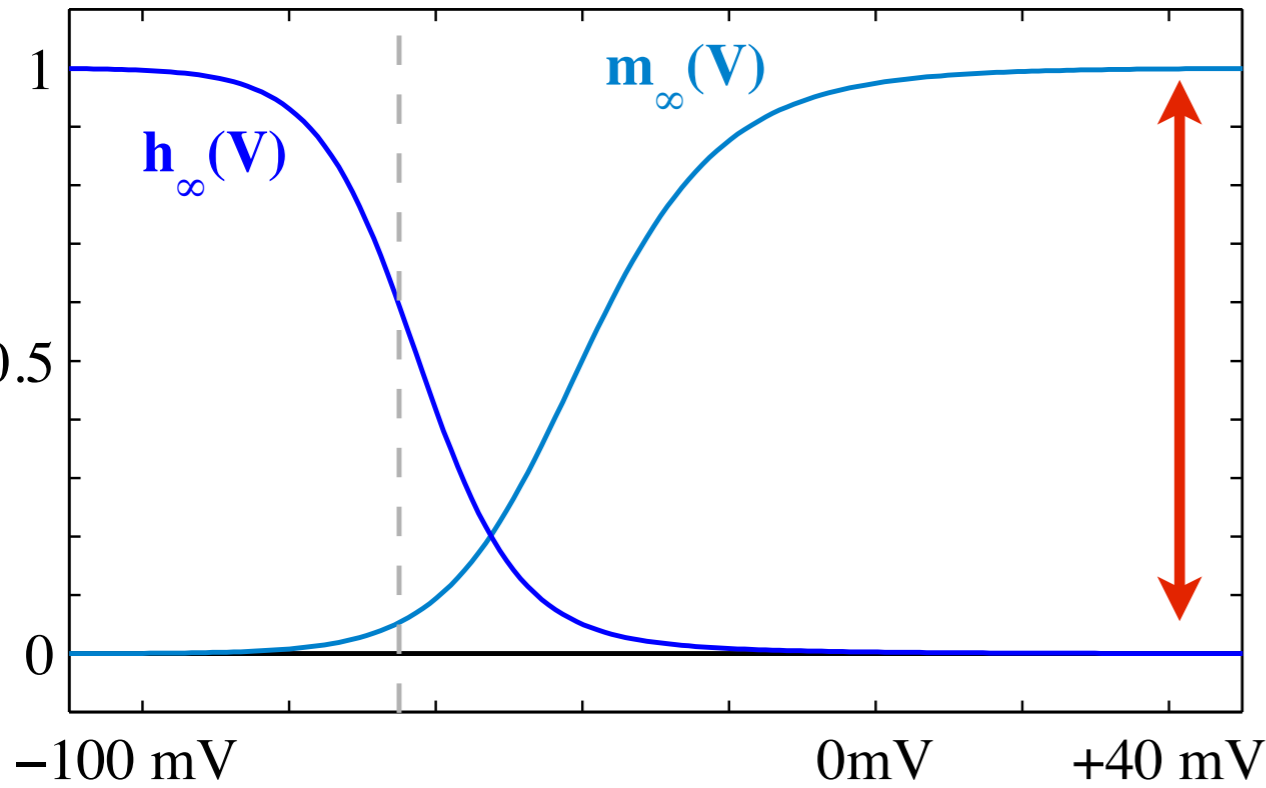

So, when neuron is depolarized ... $m \sim 1$ (open) & $h \sim 0$ (closed)

Na⁺

activation gates

m^3

3 gates ...

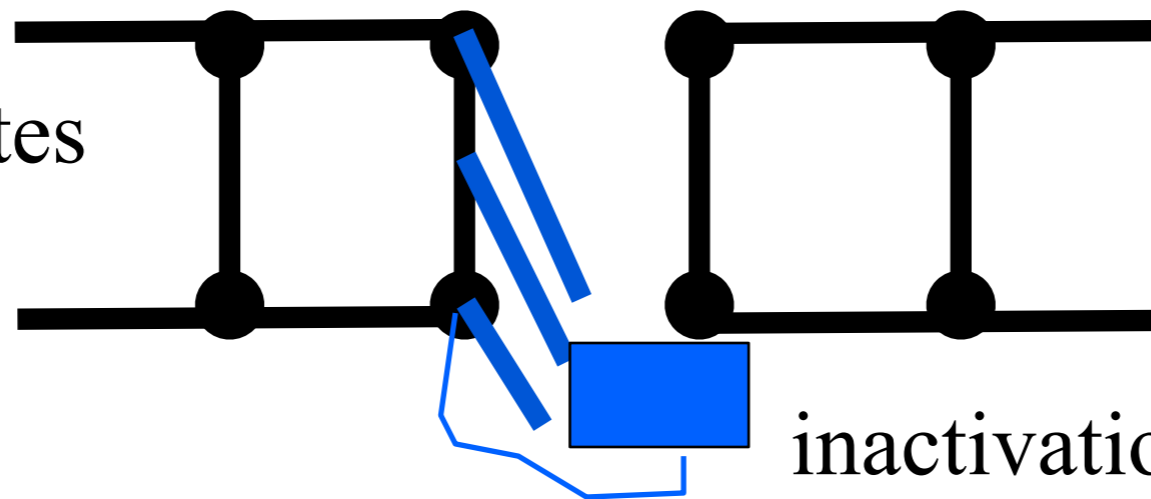

inactivation gate h 1 gate ...

Q: Can ions pass?

Modeling the voltage: Na⁺ gating variables

steady state values for Na

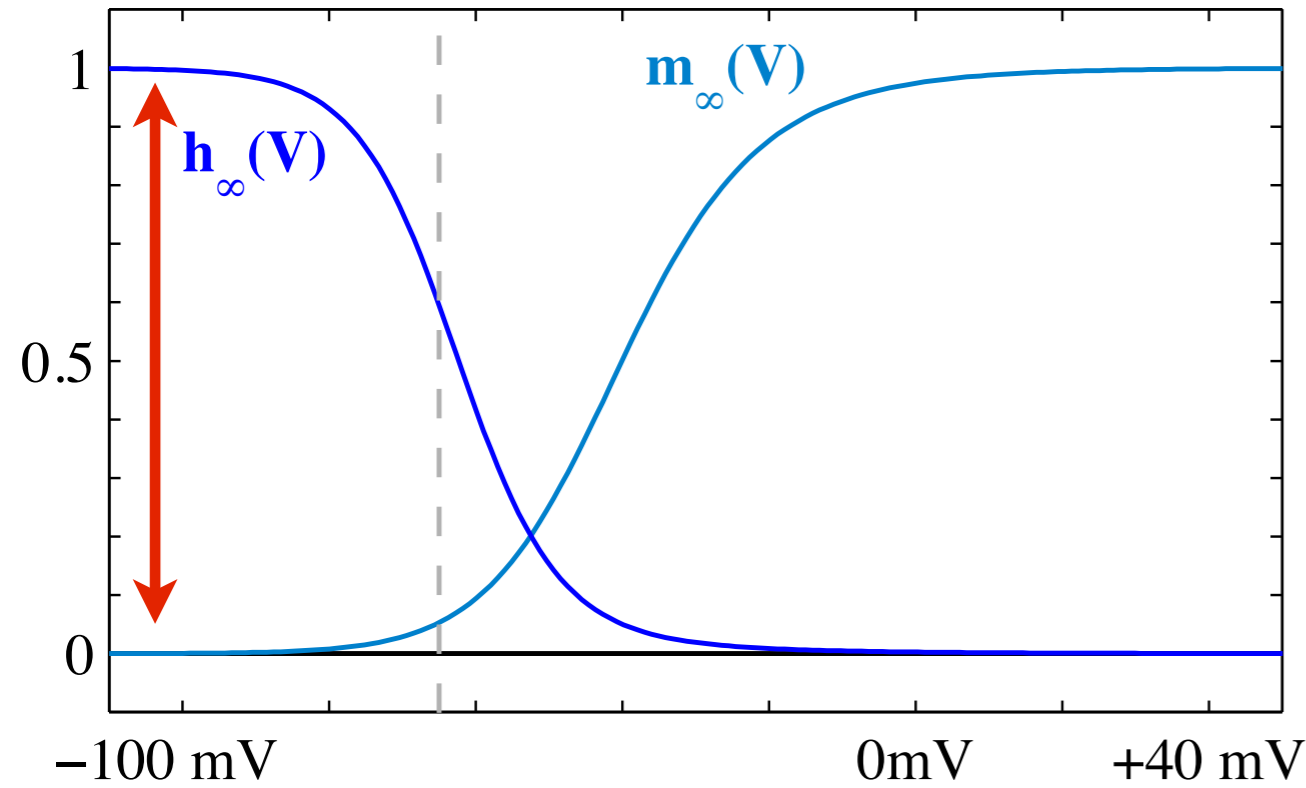

time constants for Na.

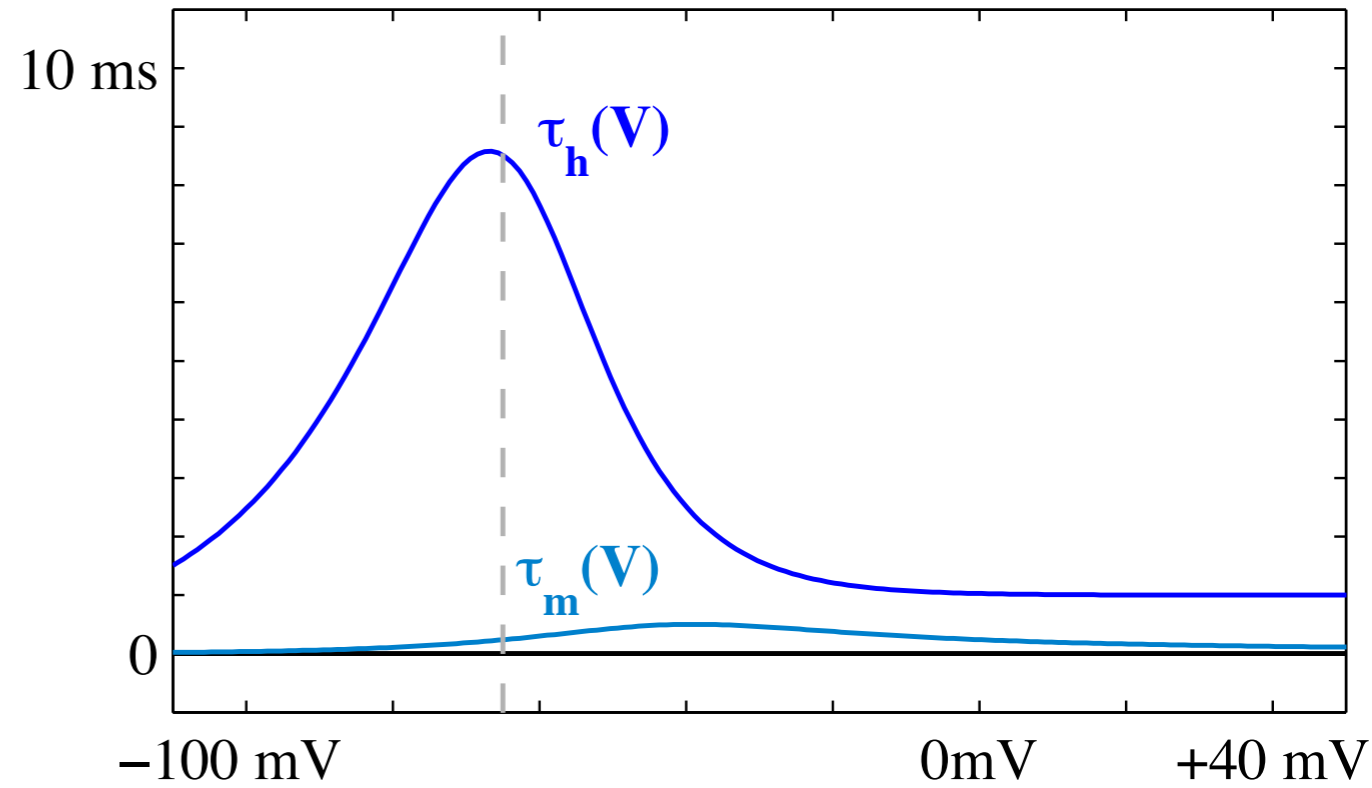

So, when neuron is hyperpolarized ... $m \sim 0$ (closed) & $h \sim 1$ (open)

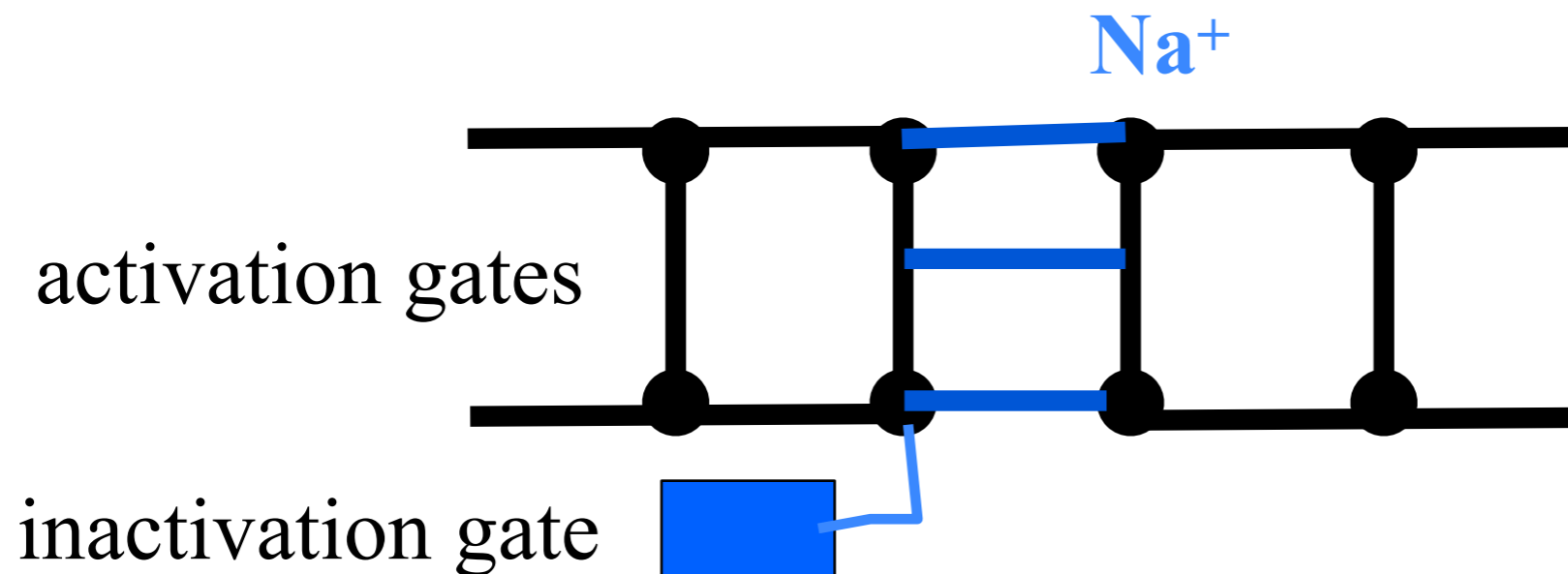

Q: Can ions pass?

Modeling the voltage: Na⁺ variable conductances

Q: How do Na⁺ ions get through channel?

A: Timescales matter.

time constants for Na.

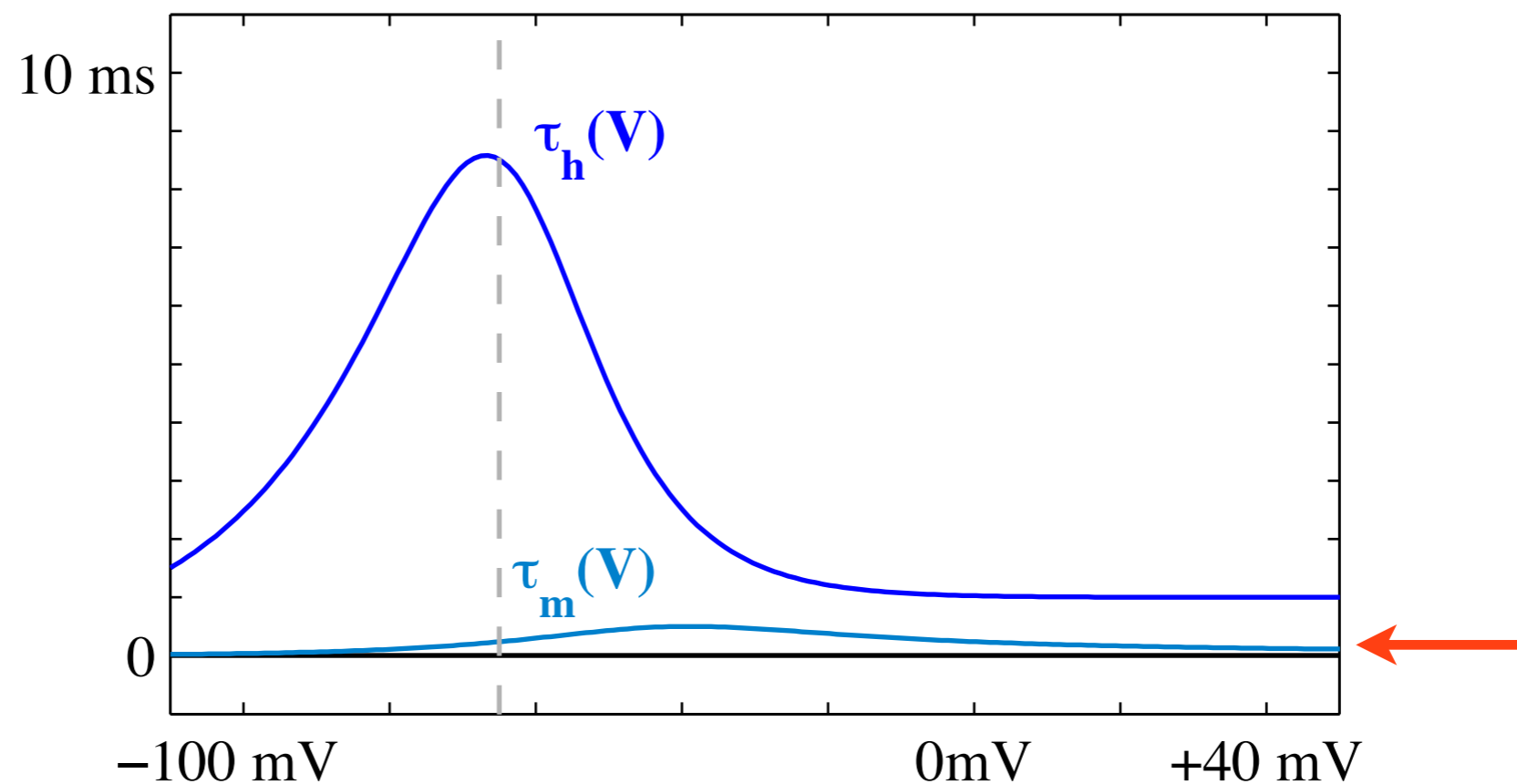

Note: Compared to the inactivation gate (h), the activation gate (m) is ...
much faster
We'll examine implications in simulation ...

Summary

Put it all together:

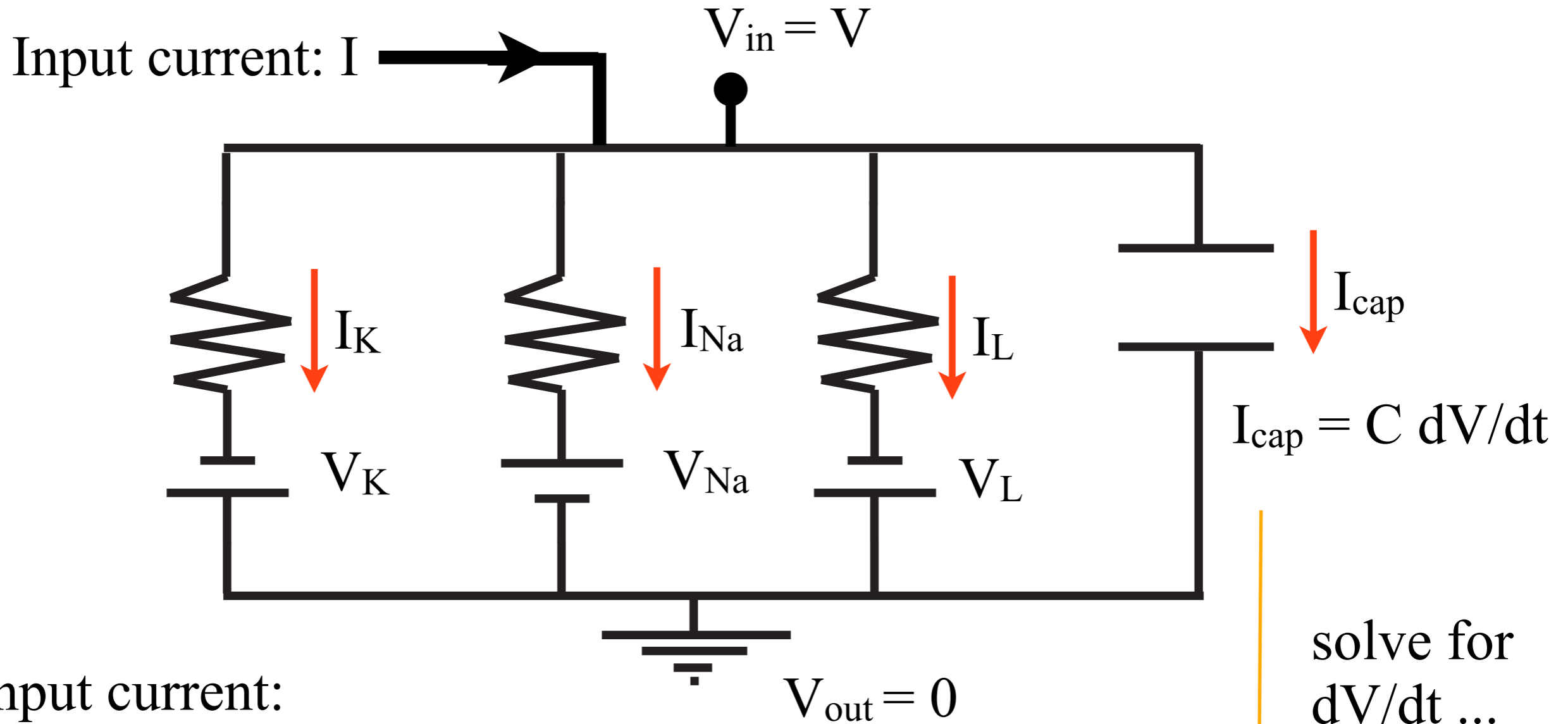

Input current:

$$I = I_{K} + I_{Na} + I_{L} + I_{cap}$$

potassium current

$$I_{K} = \bar{g}_{K} * n^4 (V - V_{K})$$

sodium current

$$I_{Na} = \bar{g}_{Na} * m^3 h (V - V_{Na})$$

leak current

$$I_{L} = g_{L} (V - V_{L})$$

Model: Hodgkin-Huxley equations

$$\begin{array}{l}
 C \frac{dV}{dt} = I_{\text{input}}(t) - \bar{g}_{\text{K}} n^4 (V - V_{\text{K}}) - \bar{g}_{\text{Na}} m^3 h (V - V_{\text{Na}}) - \bar{g}_{\text{L}} (V - V_{\text{L}}) \\
 \frac{dn}{dt} = - \frac{n - n_{\infty}(V)}{\tau_n(V)} \\
 \frac{dm}{dt} = - \frac{m - m_{\infty}(V)}{\tau_m(V)} \\
 \frac{dh}{dt} = - \frac{h - h_{\infty}(V)}{\tau_h(V)},
 \end{array}$$

voltage dynamics

| gate dynamics

steady state functions & time constants

$$\mu_{\infty}(V) = \frac{\alpha_{\mu}(V)}{\alpha_{\mu}(V) + \beta_{\mu}(V)}, \quad \tau_{\mu}(V) = \frac{1}{\alpha_{\mu}(V) + \beta_{\mu}(V)} \quad \text{for } \mu = n, m, h.$$

where

$$\begin{array}{lll}
 \alpha_n(V) = \frac{0.1 - 0.01(V + 65)}{e^{1 - 0.1(V + 65)} - 1} & \alpha_m(V) = \frac{2.5 - 0.1(V + 65)}{e^{2.5 - 0.1(V + 65)} - 1} & \alpha_h(V) = 0.07e^{(-V - 65)/20} \\
 \beta_n(V) = 0.125e^{(-V - 65)/80} & \beta_m(V) = 4e^{(-V - 65)/18} & \beta_h(V) = \frac{1}{e^{3 - 0.1(V + 65)} + 1}
 \end{array}$$

Model: Hodgkin-Huxley equations

Arguably, the most important computational model in neuroscience.

– Nobel prize, 1963

The basis for more complex models ...

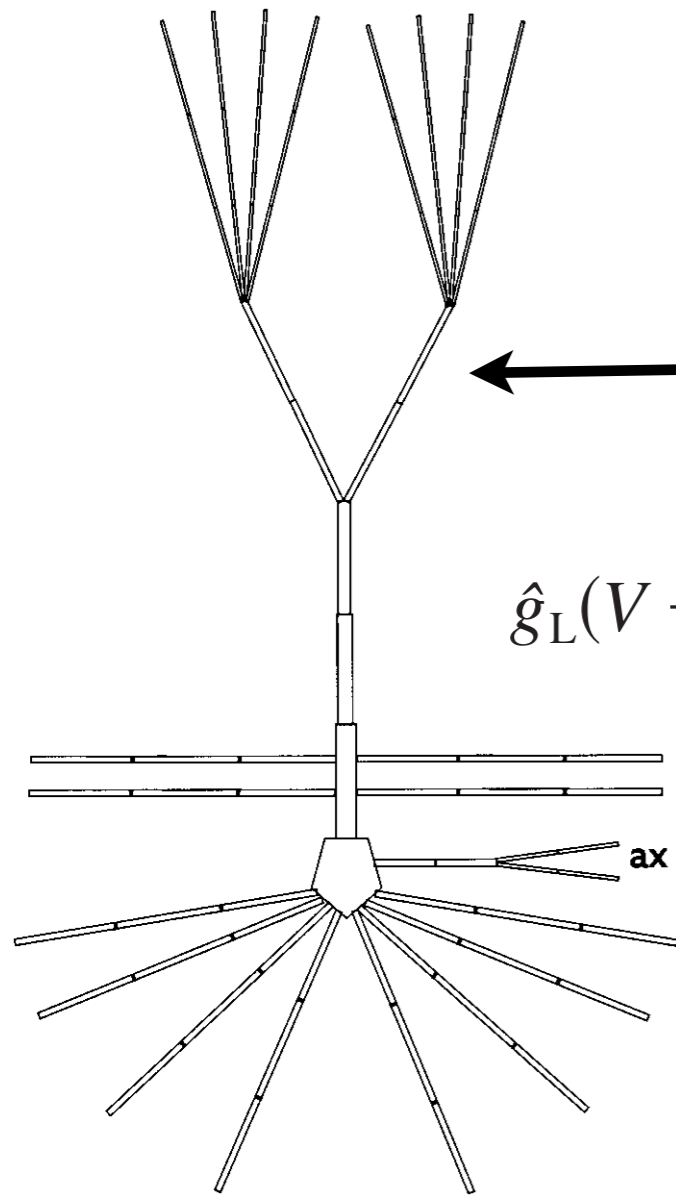

$$\leftarrow C_k \frac{dV_k}{dt} = \sum_m \gamma_{m,k} (V_m - V_k) - I_{\text{ionic},k}$$

$$\begin{aligned} & \hat{g}_L (V + 70) + [\hat{g}_{\text{Na(F)}} m_{\text{Na(F)}}^3 h_{\text{Na(F)}} + \hat{g}_{\text{Na(P)}} m_{\text{Na(P)}}] (V - 50) \\ & + [\hat{g}_{\text{K(DR)}} m_{\text{K(DR)}}^4 + \hat{g}_{\text{K(A)}} m_{\text{K(A)}}^4 h_{\text{K(A)}} + \hat{g}_{\text{K2}} m_{\text{K2}} h_{\text{K2}} + \hat{g}_{\text{K(M)}} m_{\text{K(M)}}] \\ & + \hat{g}_{\text{K(C)}} m_{\text{K(C)}} \Gamma(\chi) + \hat{g}_{\text{K(AHP)}} m_{\text{K(AHP)}}] (V + 95) \\ & + [\hat{g}_{\text{Ca(T)}} m_{\text{Ca(T)}}^2 h_{\text{Ca(T)}} + \hat{g}_{\text{Ca(H)}} m_{\text{Ca(H)}}^2] (V - 125) + \hat{g}_{\text{AR}} m_{\text{AR}} (V + 35) \end{aligned}$$

Model: Hodgkin-Huxley equations

Challenges:

– It's complicated:

- 4-dimensional
- Many parameters impacting dynamics

The price for biological realism

Python